



Thorloc Pipe Clamp Connectors

Serving The Nuclear Industry



www.thorburnflex.com



THORLOC Assembly / Disassembly

Assembly

Inspect components prior to assembly

Hub and seal ring seating surfaces must be clean and free from foreign matter. Damage to hub seats and seal lips is not acceptable, and should be rectified before assembly.

Lubricate

Usually seal rings are coated which acts as lubricant during make-up. If required light oil or MoS₂ spray can be used on hub sealing surface but not on seal ring. Take care that no solid particles are present in the lubricant.

Check seal ring stand-off

The seal ring should rock slightly against hub face. Stand-off dimensions given below in inches.

Assemble components

Install seal ring into the hubs, and assemble clamps around the hubs. Lubricant applied to the hub/clamp contact area will aid assembly. The stud bolts should be fitted ensuring that spherically faced nuts locate into spherical seats of the clamps. Lubrication of nut faces and bolt threads is recommended.

Tighten bolts in uniform manner

Bolting should be tightened to keep spacing between clamp halves approximately equal. Clamp segments should be shocked with suitable soft-faced hammer to aid assembly. Always re-tighten bolts after shocking to the torque/preload values given on facing page.

Align hubs

Hubs should be aligned so that seal ring can be installed between hubs. Do not attempt to correct badly misaligned piping by clamping force alone; piping pulling forces should only be released when clamp is fully assembled.

Complete THORLOC make up requires two conditions.

1) Hubs must be completely face to face with the rib of the seal ring where standard hubs are used and completely face to face with each other where recessed hubs are used.

2) Bolts are made up to the correct torque.

Disassembly

De-pressurize the line

Always check, never take it for granted that the line has been de-pressurized. Proceed with caution in case seepage has caused pressure to build up again.

Slacken nuts but do not remove the nuts from the bolts - then slacken clamp segments

Gradually run the nuts back along the bolts until just loose. If clamp segments remain bound onto hubs, then both segments must be slackened by hitting the inner face of the clamp lugs with a suitable soft-faced hammer.

Repeat slackening procedure

Re-loosen nuts and re-slacken both clamp segments until the maximum nut travel shown below is reached. This should release seal ring contact and any residual pressure will then be released through, with the joint.

Check clamps are slack and free to rotate and rock about hubs

Do not proceed until discharge ceases ensure that hubs are apart, seal ring is free to move and clamps are slack, free to rotate or rock.

NOTE - If pressure is still in the line, the seal ring might remain seated, making the joint tight even though it is part disassembled. When all components are loose and the clamps are free to move can dis-assembly be completed. If the components are not free to move DO NOT CONTINUE - contact your supervisor.

Bolt Torque Requirements

Clamp Size	Stud Bolt Size	Stud Bolt Length (Inches)	Average Torque
1	1/2 - 13UNC-2	3 1/2	17
1 1/2	5/8 - 11UNC-2	5	35
2	3/4 - 10UNC-2	5 1/4, 6	55
2 1/2	3/4 - 10UNC-2	5 1/4, 6	55
3	3/4 - 10UNC-2	5 1/4, 6	55
4	7/8 - 9UNC-2	7, 6 3/4	90
6	1 1/8 - 8N-2	9 3/8	205

How Thorburn THORLOC Connectors Work

THORLOC is an innovative pipe clamp connector which allows quick connect and disconnect capabilities and is an ideal connector where space, weight and joint integrity are critical requirements. These features make THORLOC a superior alternative to ANSI & DIN flanges.

THORLOC pipe clamp connectors are designed to be interchangeable with Grayloc type pipe clamp connectors. Thorburn's THORLOC is designed and registered to meet all the requirements of ASME Section III, Class 1, 2, 3, 6, CSA Can 3 N285.0 and ASME Section VIII division 1 & 2.

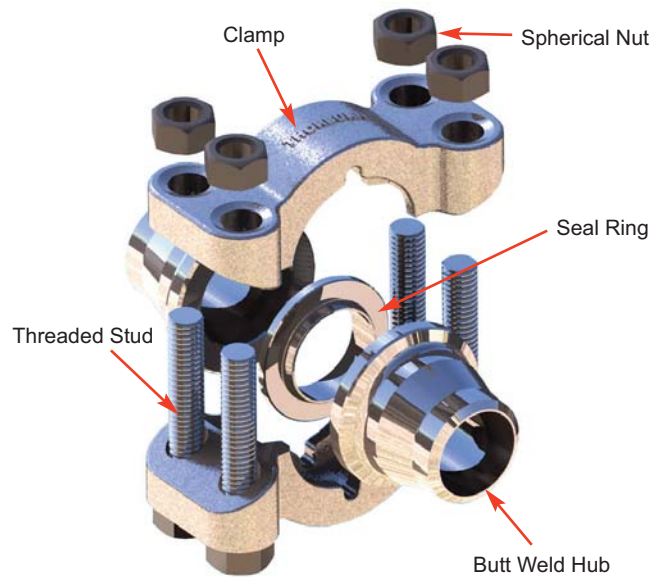

THORLOC is a four bolt pipe clamp connector consisting of two butt weld hubs that are welded to connecting pipes, two clamps (180° segments) which are rotated around the hubs and one sealing ring which fits between the two hubs.



The sealing ring is an inverted "T" with the run portion having two conicle surfaces. The conicle surfaces of the sealing ring interface against the hub sealing surface to provide a metal-to-metal seal.

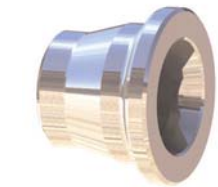

The conicle portion of the sealing ring slides into the hub and engages the seal by elastically deflecting against the hub's sealing surfaces.

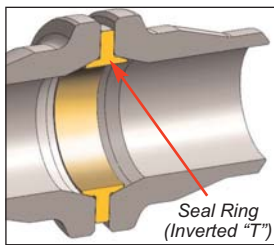

THORLOC pipe clamps fit over the hubs and as the nuts are torqued the clamps draw the hubs together.



The bolt set consists of four studs and four spherically faced nuts which mount the clamps over the hubs and engages the assembly.



Thorburn THORLOC Pipe Clamp cut-away fully assembled



THORLOC Sealing Advantage

Thorburn's THORLOC four main components include, hubs, seal ring, clamps and bolting. THORLOC does not rely on the conventional flange gaskets or correctly tensioned bolting to maintain seal integrity. When bolting the assembly, the hubs are drawn together by the twin wedge action of the two clamp segments compressing on the seal ring to make a self-energizing seal.

THORLOC seal ring and hubs are made of different materials having their own unique hardness and thermal properties that enhances the seal as temperature changes are encountered. In service the seal ring becomes even more effective as internal pressure reinforces the metal-to-metal seal to the extent that its strength can normally exceed the burst pressure of the connected pipe.

Withstanding External Pipe Loads

External bending forces are an inevitable part of any piping system, resulting in high stresses being placed on pipe joints. THORLOC's applied bolting loads are transmitted to the clamps through almost 360° contact with the hubs. As the bolts are transversely mounted they are almost completely isolated from the operating loads, resulting in a strong, reliable yet compact connection. This feature allows THORLOC to withstand considerable bending forces and axial loading under pressure without leaking or the bolts becoming loose, greatly reducing maintenance costs at the same time as being highly beneficial to the environment.

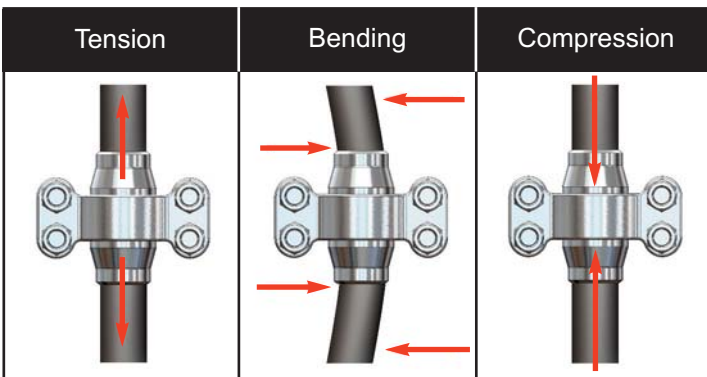

Thorburn's THORLOC pipe clamp connector, as compared to convention ANSI flanges, are capable of withstanding higher tensile loads, more severe bending loads and prevent compressive force overloads, all the while, maintaining a gas tight seal.

THORLOC Pipe Connectors can be used in applications where design pressures up to 30,000 psi are found. THORLOC's energized seal, light weight, compactness and simplicity to install make it an extremely versatile and value added pipe connector.

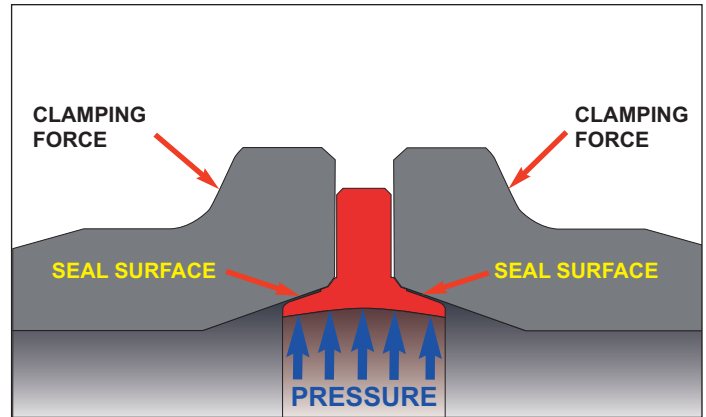

After Assembly: Pressure Energized Seal

THORLOC Pipe Clamp Benefits

- Up to 75% lighter and significantly smaller than ANSI flanges
- 25% smaller clamp diameter & 40% shorter connection length
- Easier fabrication and installation with no bolt holes to align
- Only 4 bolts to tighten rather than up to 24 on an ANSI flange
- THORLOC can be rotated around the hub for easy bolt orientation and tightening
- Ancillary components such as valves and piping layouts can be installed without worrying about bolt hole alignment
- Quicker and easier make-up and breakout minimizes maintenance downtime
- Lower bolt torque: typically 50% less than that for a ring joint flange
- Sealing integrity is unaffected by over-tensioning bolts
- THORLOC can be assembled or disassembled in the time it takes for a single ANSI flange connection
- It is not usually necessary to re-tighten bolts once in service
- One clamp size is required for each nominal pipe size
- Reusable seal rings give greater flexibility for hydro-testing and commissioning prior to service
- Available in standard 316 stainless steel (other materials available upon request)

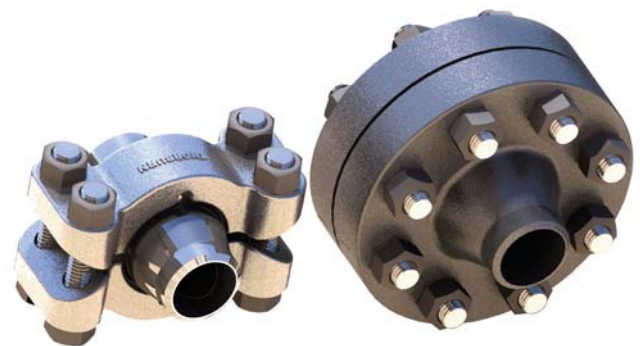

THORLOC 2 inch Pipe Clamp Connector

ANSI 2 inch 2500 lbs Flange Connector

THORLOC Butt Weld Hub

THORLOC Butt Weld Hubs are usually supplied ready to be welded to pipe or as an integral connector on any associated piping equipment. During assembly as the clamps draw the hubs together using the angular outer shoulders of the hubs, the seal ring is deflected against the hub seating surfaces creating a pressure tight seal. Internal pressure reinforces this seal so that it is both self energized and pressure sealed.

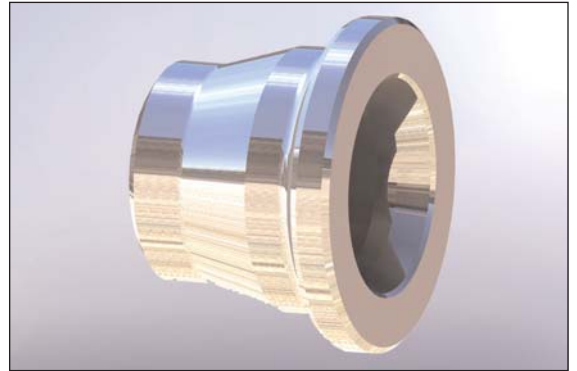

Technical Data

Material: SA-479 Type 316/316L
Design Pressure: 3700 psig (255 bar)
Design Temperature: 450°F (232°C)

NUCLEAR CLASS:

To Specify ASME Section III Code Class - Replace "X" with NC1 (Class 1), NC2 (Class 2), NC3 (Class 3).

For Class 6 (Leave Blank)

For ordering information - See back cover

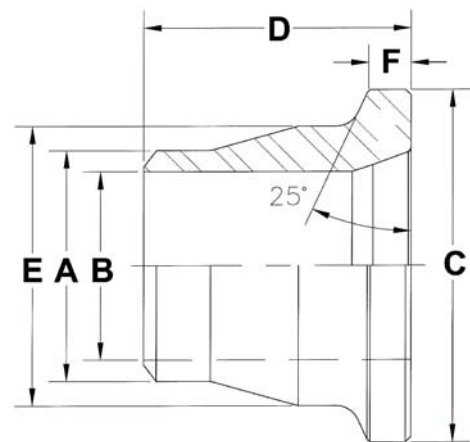

Nom Pipe Size	Schedule or Weight	Stainless Steel Part Number	Approx Weight (lbs)	Seal Ring Size	Clamp Size (Inches)	Pipe OD	Pipe ID	Dimensions (Inches)			
						A	B	C	D	E	F
1	80	N1616TL-80-BWH-S6-X	0.54	11	1	1.315	0.957	2.000	1.750	1.500	0.313
	160	N1616TL-160-BWH-S6-X	0.66	7	1	1.315	0.815	2.000	1.750	1.500	0.313
1 1/2	80	N2424TL-80-BWH-S6-X	1.83	14	1 1/2	1.900	1.500	3.125	2.375	2.375	0.437
	160	N2424TL-160-BWH-S6-X	2.01	14	1 1/2	1.900	1.338	3.125	2.375	2.375	0.437
2	80	N3232TL-80-BWH-S6-X	2.59	20	2	2.375	1.939	3.625	2.750	2.875	0.437
	160	N3232TL-160-BWH-S6-X	2.93	20	2	2.375	1.689	3.625	2.750	2.875	0.437
2 1/2	80	N4040TL-80-BWH-S6-X	6.36	25	2 1/2-3	2.875	2.323	5.000	3.250	4.000	0.500
	160	N4040TL-160-BWH-S6-X	7.16	20	2 1/2-3	2.875	2.125	5.000	3.250	4.000	0.500
3	80	N4848TL-80-BWH-S6-X	5.50	27	2 1/2-3	3.500	2.900	5.000	3.250	4.000	0.500
	160	N4848TL-160-BWH-S6-X	6.53	25	2 1/2-3	3.500	2.624	5.000	3.250	4.000	0.500
4	80	N6464TL-80-BWH-S6-X	7.80	40	4	4.500	3.826	6.000	3.625	5.000	0.500
	160	N6464TL-160-BWH-S6-X	10.13	34	4	4.500	3.438	6.000	3.625	5.000	0.500
6	80	N9696TL-80-BWH-S6-X	24.17	62	6	6.25	5.761	9.250	4.625	7.750	0.750
	160	N9696TL-160-BWH-S6-X	33.19	52	6	6.25	5.187	9.250	4.625	7.750	0.812

THORLOC Seal Ring

THORLOC Seal Rings are seated between the two hubs deflecting elasticity against the hub sealing surfaces forming a pressure-energized metal-to-metal seal. Seal Rings are coated with Molybdenum Disulfide (MoS₂) which acts as a lubricant during make-up. The seal ring rib ensures proper face-to-face alignment with the hubs in the make-up position forming a pressure tight seal. With careful handling, seal rings are reusable.



Technical Data

Material: SA-564 Grade 630, MoS₂ Coating
Design Pressure: 3700 psig (255 bar)
Design Temperature: 450°F (232°C)

NUCLEAR CLASS:

To Specify ASME Section III Code Class - Replace "X" with NC1 (Class 1), NC2 (Class 2), NC3 (Class 3), For Class 6 (Leave Blank)
 For ordering information - See back cover

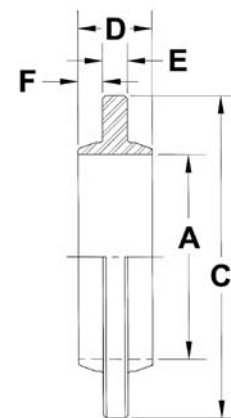

Nom Pipe Size	Schedule or Weight	Seal Ring Size	Part Number	Approx Weight (lbs)	Dimensions (Inches)				
			AISI 630 (17-4 PH) Stainless Steel		A	C	D	E	F
			MoS ₂ With Graphite Coated						
1	80	11	N16TL-80-SRG-11-S564-X	0.08	1.125	1.734	0.375	0.125	0.125
	160	7	N16TL-160-SRG-7-S564-X	0.06	0.906	1.375	0.375	0.125	0.125
1 1/2	80	14	N24TL-80-SRG-14-S564-X	0.31	1.610	2.625	0.563	0.250	0.156
	160	14	N24TL-160-SRG-14-S564-X	0.31	1.610	2.625	0.563	0.250	0.156
2	80	20	N32TL-80-SRG-20-S564-X	0.50	2.063	3.250	0.750	0.250	2.063
	160	20	N32TL-160-SRG-20-S564-X	0.50	2.063	3.250	0.750	0.250	2.063
2 1/2	80	25	N40TL-80-SRG-25-S564-X	0.70	2.672	4.000	0.750	0.250	2.672
	160	20	N16TL-160-SRG-20-S564-X	0.50	2.063	3.250	0.750	0.250	2.063
3	80	27	N48TL-80-SRG-27-S564-X	0.70	3.063	4.250	0.750	0.250	3.063
	160	25	N48TL-160-SRG-25-S564-X	0.70	2.672	4.000	0.750	0.250	2.672
4	80	40	N64TL-80-SRG-40-S564-X	1.28	4.063	5.500	1.000	0.250	4.063
	160	34	N64TL-160-SRG-34-S564-X	0.89	3.688	5.000	0.750	0.250	3.688
6	80	62	N96TL-80-SRG-62-S564-X	4.0	6.065	7.875	1.375	0.375	0.500
	160	52	N96TL-160-SRG-52-S564-X	1.65	5.313	6.625	1.000	0.250	0.375

THORLOC Clamp Assembly

THORLOC Clamp Assemblies are comprised of two 180° clamp sections which make contact through a full 360° around the hubs and can be rotated around the hubs to fit the most practical installation position allowing greater flexibility during installation. With just four standard sized bolts, assembly and disassembly procedures are quick and safe. Bolts are supplied with spherical-faced nuts which eliminate bending stresses.



Technical Data

CLAMPS

Material: SA-479 Type 316/316L

BOLTS

Material: SA-193 B8M T316/316L

NUTS

Material: SA-194 8M T316/316L

NUCLEAR CLASS:

To Specify ASME Section III Code Class - Replace "X" with NC1 (Class 1), NC2 (Class 2), NC3 (Class 3), For Class 6 (Leave Blank)

For ordering information - See back cover

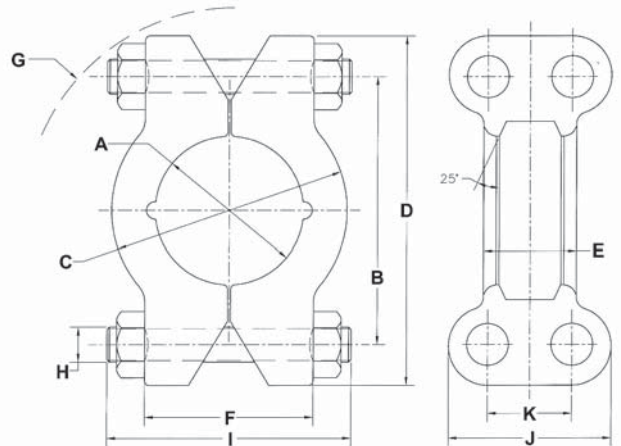

Clamp Size	PN Assembly with Bolting	App. Weight (lbs)	Dimensions (Inches)										
	Stainless Steel		A	B	C	D	E	F	G	H	I	J	K
1	N16TL-CLP-S6-X	3.5	1.687	3.187	2.813	4.250	1.375	2.250	2.625	1/2	3.500	2.313	1.250
1 1/2	N24TL-CLP-S6-X	10.3	2.687	5.000	4.500	6.500	2.000	3.250	4.000	5/8	5.000	3.125	1.625
2	N32TL-CLP-S6-X	14.2	3.188	5.750	5.062	7.500	2.000	3.625	4.500	3/4	5.250	3.500	1.813
2 1/2	N40TL-CLP-S6-X	21.5	4.375	7.500	6.875	9.250	2.375	4.500	5.250	3/4	6.000	3.500	1.813
3	N48TL-CLP-S6-X	21.5	4.375	7.500	6.875	9.250	2.375	4.500	5.250	3/4	6.000	3.500	1.813
4	N64TL-CLP-S6-X	33.0	5.375	8.500	8.125	10.500	2.375	5.250	6.000	7/8	7.000	4.063	2.063
6	N96TL-CLP-S6	68.0	8.375	12.625	12.000	15.000	3.500	6.625	8.750	1 1/8	9.375	4.813	2.437

THORBURN FLEX - Canada
 165 Oneida, Pointe-Claire, Quebec
 Canada, H9R 1A9
 Tel: +1-514-695-8710
 Fax: +1-514-695-1321
 sales@thorburnflex.com
 1-800-363-6613
 (Toll Free North America)



ISCIR Romania | CNCAN Romania | EN 13480-2002 | HAF 604 China | TSG China
 (CRN for all Canadian provinces)

How To Order Thorburn Thorloc Pipe Clamp Connectors

Butt Weld Hubs:

N3232TL - 80 - BWH - S6 - NC3

- Size - 2 inch
- Schedule/Weight - 80
- Component - Butt Weld Hub
- Material - SA-479 Type 316/316L
- Nuclear Class - Class III (for Class VI - Leave Blank)

Seal Rings:

N32TL - 80 - SRG - 20 - S564 - NC3

- Size - 2 inch
- Schedule/Weight - 80
- Component - Seal Ring
- Seal Ring Size - 20
- Material - SA-564 Grade 630 with MoS₂ Coating
- Nuclear Class - Class III (for Class VI - Leave Blank)

Clamps:

N32TL - CLP - S6 - NC3

- Size - 2 inch
- Component - Clamp
- Material - SA-479 Type 316/316L
- Nuclear Class - Class III (for Class VI - Leave Blank)

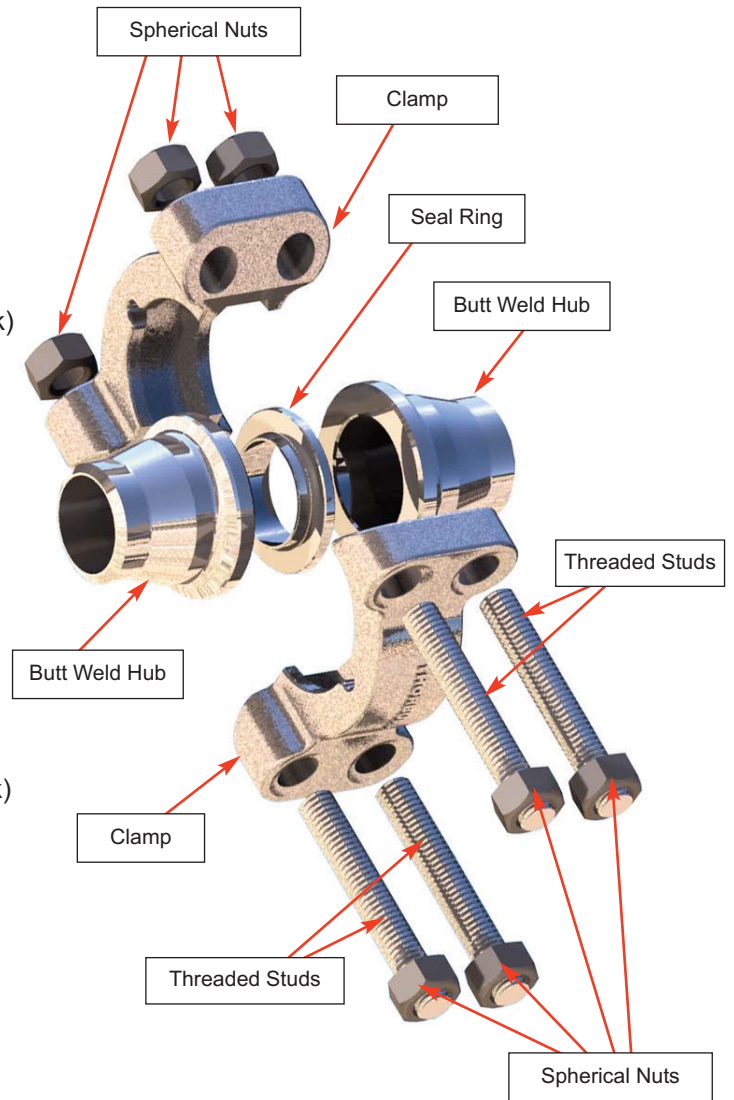

*Over 50 years of flexible piping experience
 waiting to serve you...*